



Tips for Minimizing Troublesome Problems with Voltage Regulator Paralleling Circuits

Anyone who has commissioned generation plants has likely experienced the frustration of circulating currents between generators connected in parallel. The problem most often can be pinpointed to a misconnection of the paralleling circuit that interfaces the current and the potential transformer to the excitation system. The phase relationship between the current and the sensed voltage is important to ensure reactive power sharing (VAR) between multiple machines, and/or the utility bus.

During commissioning, only one solution exist for the excitation system to achieve reactive power sharing (VAR). The current must lag the sensed voltage by 90 electrical degrees at unity power factor. See Figure 1.

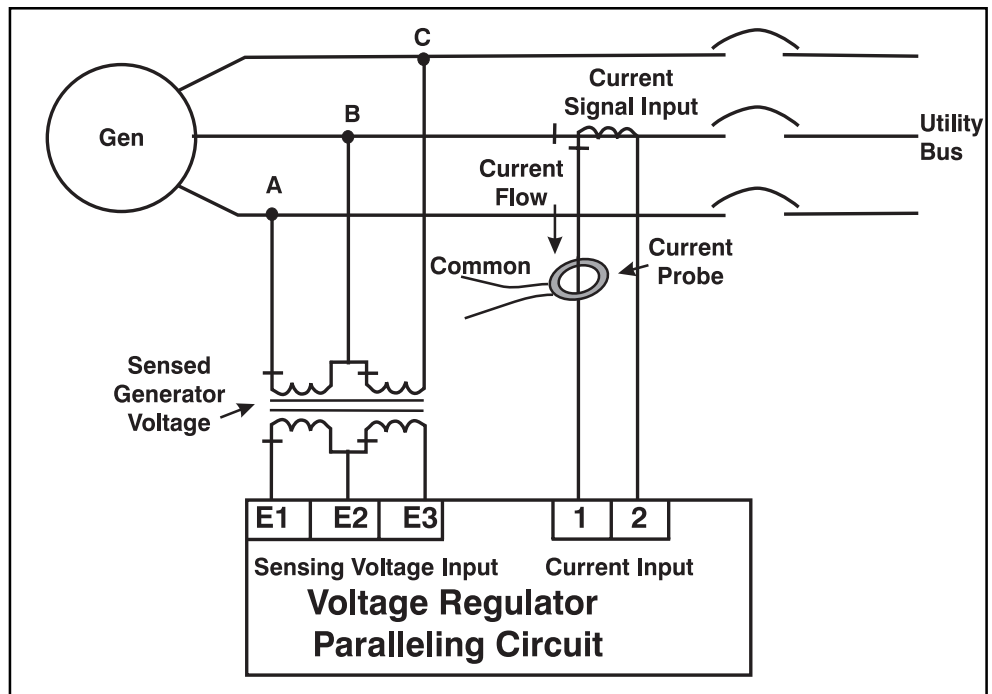

Figure 2: Typical Voltage Regulator Parallel Circuit Connection

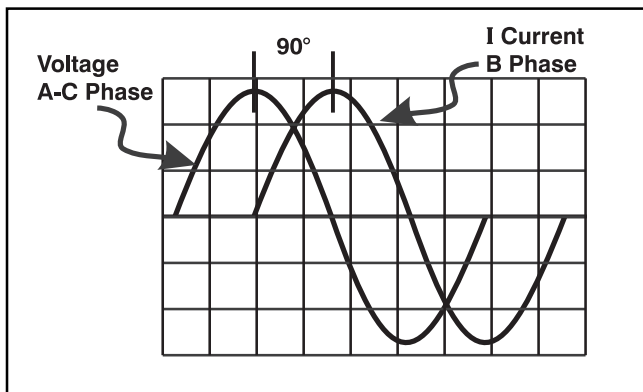

Figure 1: A and C Sensed Voltage Relationship to B Phase Line Current at Unity Power Factor

To accommodate the proper phase shift, the potential transformer used for voltage sensing must be connected in quadature with the current transformer. Specifically, the generator sensed voltage connects to phases A and C for single phase voltage sensing, while B phase line current provides the CT signal to the voltage regulator. For three phase voltage sensing, the B phase voltage connects to the same line as the current signal.

Besides orientation of the PT and CT, polarity plays an important role in proper generator paralleling. Figure 2 highlights the proper connection of the excitation system paralleling circuit. Note the polarity of the PTs and CT as they are oriented. Wrong polarities of either the PTs or CT will cause the generator to become quickly overexcited, and connecting generators to become underexcited.

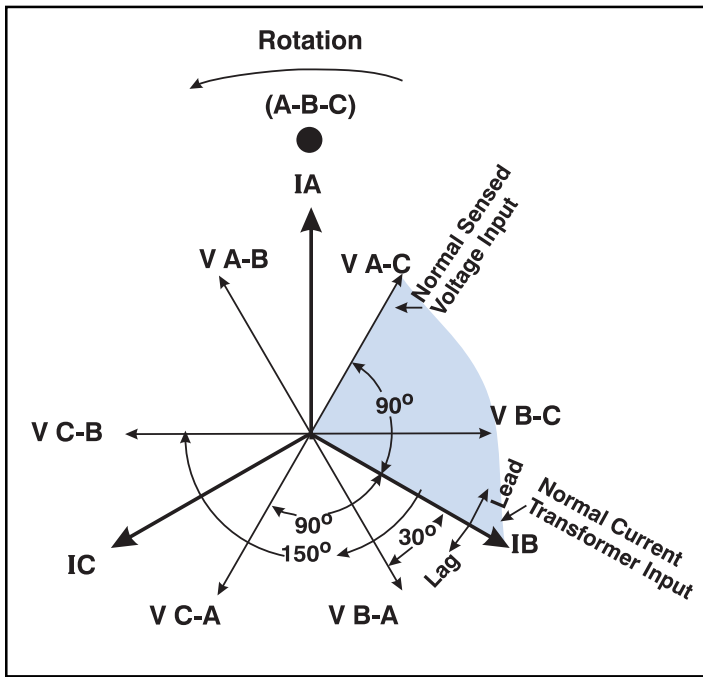

Figure 3: Voltage and Current Transformer Phase Angle at Unity Power Factor

The phasor diagram shown in Figure 3 highlights the correct relationship of PT and CT phasing. Notice how the current vector lags the voltage vector by 90 electrical degrees when the sensed voltage has been derived from phases A and C and the current from B phase. This phasor relationship can only be satisfied with the generator operating at unity power factor. Should an inductive load be applied, the current vector will now lag the voltage vector by a magnitude dependent upon the power factor of the load. Internally, the voltage regulator sums the voltage and current phasor, and it appears as though the generator voltage has increased. See Figure 4. Hence, the resulting action from the voltage regulator causes a slight decrease in field excitation, producing voltage droop in the system. Generally the droop is established for 5% at rated load, rated power factor.

Imagine now if the current phasor in B phase were rotated 180 degrees in Figure 3. What happens to the voltage regulator output under the same conditions

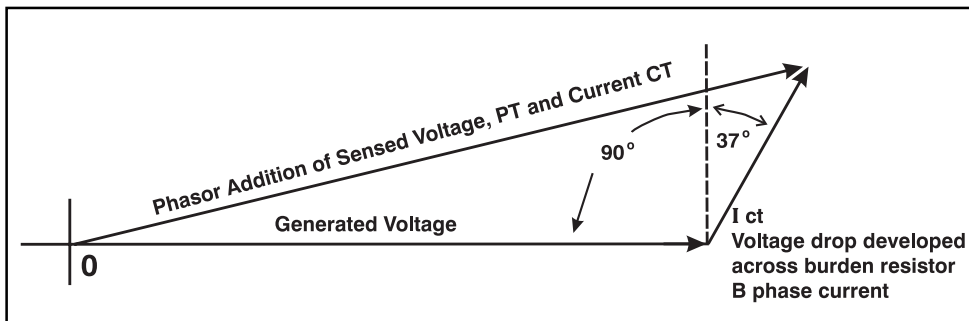

Figure 4: Phasor Sum of Voltage and Current with .8 P.F. Lagging Generator Load

when the current now leads the voltage instead of lagging? Instead of decreasing slightly the field excitation, an increase in field excitation will occur. If the generator were connected to another machine, the complementing machine will become underexcited and circulating currents will flow between generators.

Testing for Proper Phasing

Multiple methods are available to verify correct phase shift between PTs and the CT. An excellent method involves the use of a two channel isolated oscilloscope that can measure voltage and current with the help of a current probe. The procedure below outlines the steps involved.

Most excitation systems are equipped with a manual voltage control used for backup or startup commissioning. "If manual control is available, perform these tests in manual" to verify proper phase angle between the PT and CT circuits.

Prior to paralleling the generator, null the automatic voltage regulator to manual control and follow appropriate procedures to parallel the generator to the bus.

- Step 1. Establish the following system conditions:
Power Level - ~25% kW
Power Factor - 1.0 (zero kVAr)
- Step 2. Connect the oscilloscope channel 1 scope probe to the voltage regulator E1 and common to E3 on the voltage regulator.
- Step 3. Connect channel 2 scope to the current probe noting polarity. (Typically, the red lead current probe will go to channel 2 and the black lead to common of channel 2.)

Set the oscilloscope for dual channel operation and compare the time between the voltage waveform and the current waveform. Record these readings in Table 1, on page 3, and check the other phases as suggested.

Finding Solutions

Use the correction procedures in Table 2, on page 4, to find solution where the recorded readings are incompatible with correct readings shown in the table. In Table 2, E1, E2 and E3 represent voltage sensing at the voltage regulator; 1 and 2 represents CT input.

VOLTAGE REGULATOR TEST POINT	VOLTS LEAD/LAG CURRENT INPUT	TIME (mS)	PHASE ANGLE*
E1-E3	LEAD	4.16 mS	90 DEG
E2-E3	LEAD	1.39 mS	30 DEG
E1-E2	LEAD	6.94 mS	150 DEG
RECORDED DATA			
E1-E3			
E2-E3			
E1-E2			

NOTES:

* Phase angle is calculated from time between zero crossing of the two wave-forms.

For 60 Hz systems, PHASE ANGLE = TIME (mS) x 21.6

For 50 Hz systems, PHASE ANGLE = TIME (mS) x 18

Table 1: Sample Test Performed at 60 Hertz

Other Tips

Single Voltage Sensing

For single phase voltage sensing circuits, disregard E2 terminal.

VAr Drift

VArS will drift if the CT signal is marginal for the application (approximately 3 Amps). If the proper CT ratio is not available, increase the droop CT signal into the voltage regulator across the burden resistor if possible. This should reduce VAr drift caused by a marginal CT current signal.

Shorting Contacts

A shorting contact at the CT input of the voltage regulator paralleling loop is used to prevent a drop in generator voltage when the machine is isolated and local loads are maintained. It is important that these contacts do not short the current transformer signal when the generator operates in parallel with the bus or other generators

For more information

For more information, consult the Basler factory at 618/654-2341 or visit our web site at <http://www.basler.com>.

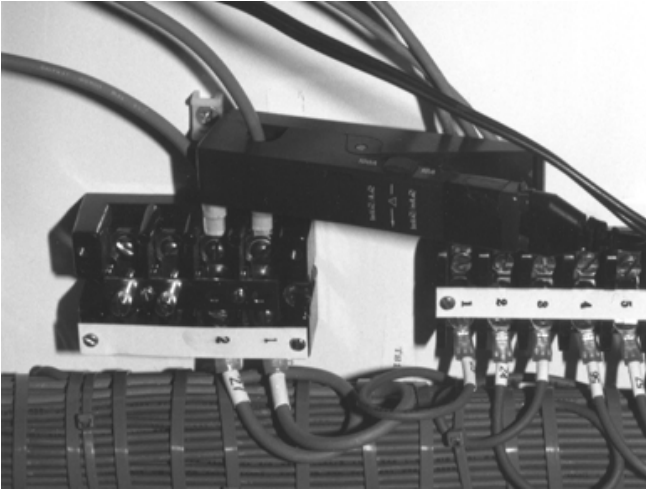

Figure 5: A current probe, as shown above, may be used in testing for the proper phasing, note direction of arrow.

PHASING CONDITION	TEST POINT	VOLTS LEAD/LAG	TIME(mS)	PHASE ANGLE*	CORRECTION PROCEDURE
1. PHASING CORRECT	E1-E3	LEAD	4.16 mS	90 DEG	NO CORRECTION REQUIRED
	E2-E3	LEAD	1.39 mS	30 DEG	
	E1-E2	LEAD	6.94 mS	150 DEG	
WHERE CHANGES IN THE CT AND PT CONNECTIONS ARE REQUIRED, SHUTDOWN GENERATOR AND MAKE CHANGES.					
2. PHASES A AND C REVERSED	E1-E3	LAG	4.16 mS	90 DEG	1. MOVE E1 TO E3 2. MOVE E3 TO E1
	E2-E3	LAG	1.39 mS	30 DEG	
	E1-E2	LAG	6.94 mS	150 DEG	
3. PHASES B AND C REVERSED	E1-E3	LEAD	6.94 mS	150 DEG	1. MOVE E2 TO E3 2. MOVE E3 TO E2
	E2-E3	LAG	6.94 mS	150 DEG	
	E1-E2	LEAD	4.16 mS	90 DEG	
4. PHASES A AND B REVERSED	E1-E3	LEAD	1.39 mS	30 DEG	1. MOVE E1 TO E2 2. MOVE E2 TO E1
	E2-E3	LEAD	4.16 mS	90 DEG	
	E1-E2	LAG	1.39 mS	30 DEG	
5. PHASES ROLLED COUNTER-CLOCKWISE	E1-E3	LAG	1.39 mS	30 DEG	1. MOVE E1 TO E2 2. MOVE E2 TO E3 3. MOVE E3 TO E1
	E2-E3	LAG	4.16 mS	90 DEG	
	E1-E2	LEAD	1.39 mS	30 DEG	
6. PHASES ROLLED CLOCKWISE	E1-E3	LAG	6.94 mS	150 DEG	1. MOVE E1 TO E3 2. MOVE E2 TO E1 3. MOVE E3 TO E2
	E2-E3	LEAD	6.94 mS	150 DEG	
	E1-E2	LAG	4.16 mS	90 DEG	
7. CT POLARITY REVERSED	E1-E3	LAG	4.16 mS	90 DEG	1. MOVE 1 TO 2 2. MOVE 2 TO 1
	E2-E3	LAG	6.94 mS	150 DEG	
	E1-E2	LAG	1.39 mS	30 DEG	
8. PHASES A AND C REVERSED + CT POLARITY REVERSED	E1-E3	LEAD	4.16 mS	90 DEG	1. MOVE E1 TO E3 2. MOVE E3 TO E1 3. MOVE 1 TO 2 4. MOVE 2 TO 1
	E2-E3	LEAD	6.94 mS	150 DEG	
	E1-E2	LEAD	1.39 mS	30 DEG	
9. PHASES B AND C REVERSED + CT POLARITY REVERSED	E1-E3	LAG	1.39 mS	30 DEG	1. MOVE E2 TO E3 2. MOVE E3 TO E2 3. MOVE 1 TO 2 4. MOVE 2 TO 1
	E2-E3	LEAD	1.39 mS	30 DEG	
	E1-E2	LAG	4.16 mS	90 DEG	
10. PHASES A AND B REVERSED + CT POLARITY REVERSED	E1-E3	LAG	6.94 mS	150 DEG	1. MOVE E1 TO E2 2. MOVE E2 TO E1 3. MOVE 1 TO 2 4. MOVE 2 TO 1
	E2-E3	LAG	4.16 mS	90 DEG	
	E1-E2	LEAD	6.94 mS	150 DEG	
11. PHASES ROLLED COUNTER-CLOCKWISE + CT POLARITY REVERSED	E1-E3	LEAD	6.94 mS	150 DEG	1. MOVE E1 TO E2 2. MOVE E2 TO E3 3. MOVE E3 TO E1 4. MOVE 1 TO 2 5. MOVE 2 TO 1
	E2-E3	LEAD	1.39 mS	30 DEG	
	E1-E2	LAG	6.94 mS	150 DEG	
12. PHASES ROLLED CLOCKWISE + CT POLARITY REVERSED	E1-E3	LEAD	1.39 mS	30 DEG	1. MOVE E1 TO E3 2. MOVE E2 TO E1 3. MOVE E3 TO E2 4. MOVE 1 TO 2 5. MOVE 2 TO 1
	E2-E3	LAG	1.39 mS	30 DEG	
	E1-E2	LEAD	4.16 mS	90 DEG	

Table 2: Three Voltage Sensing Paralleling Correction Procedure

ROUTE 143, BOX 269, HIGHLAND, ILLINOIS U.S.A. 62249
PHONE 618-654-2341 FAX 618-654-2351

P.A.E. Les Pins, 67319 Wasselonne Cedex FRANCE
PHONE (33-3-88) 87-1010 FAX (33-3-88) 87-0808

<http://www.basler.com>, info@basler.com